

Intrarow Soil Thermal Weeding
Supplemental:
Final In-Field Design for Low Energy
Consumption and High work rates

VERSION 2

August 2016. Report number 2-2016

Dr Charles N Merfield

The BHU Future Farming Centre

Permanent Agriculture and Horticulture Science and Extension

www.bhu.org.nz/future-farming-centre



Live, like you'll die tomorrow;
Farm, like you'll live for ever.

Disclaimer

This report has been prepared by The BHU Future Farming Centre, which is part of The Biological Husbandry Unit Organics Trust. While every effort has been made to ensure that the information herein is accurate, The Biological Husbandry Unit Organics Trust takes no responsibility for any errors, omissions in, or for the correctness of, the information contained in this paper. The Biological Husbandry Unit Organics Trust does not accept liability for error or fact or opinion, which may be present, nor for the consequences of any decisions based on this information.

Copyright and licensing

© The Biological Husbandry Unit Organics Trust 2017. This document is licensed for use under the terms of the Creative Commons Public Licences Attribution Non-Commercial No Derivatives Version 3.0 (<http://creativecommons.org/licenses/by-nc-nd/3.0/legalcode>). Any use of this document other than those uses authorised under this licence or copyright is prohibited.

Citation Guide

Merfield, C. N. (2016). Intra-row Soil Thermal Weeding Supplemental: Final In-Field Design for Low Energy Consumption and High work rates - Version 2. Lincoln, New Zealand: The BHU Future Farming Centre: 6



1. Introduction

Two previous reports “Expanding the Potential of Intrarow Soil Thermal Weeding” [1] and “Intrarow soil thermal weeding supplemental report: An analysis of the potential for ex-field heat treatment” [2] analysed the potential of intrarow soil thermal weeding (ISTW) as a permanent means of solving the problem of intrarow weeds in cropping systems. The reports suggested two different approaches to implementation: An in-situ / in-field design using a tunnel and rotor system similar to that used by current ISTW steam machines [1]; and an ex-situ / ex-field system based on two concurrent gas to particulate solid, counterflow, heat exchangers [2].

However, both approaches are considered to have drawbacks.

The in-field tunnel design will suffer from significant heat loss and therefore comparatively high fuel use due to the open nature of the tunnels and the difficulty effectively insulating them due to them being drawn through the soil. Also the comparatively small volume of the tunnels and the need to transfer a significant amount of heat into the soil and back out again using air as the transfer medium is considered challenging from an engineering perspective. This means that forward speeds are likely to be limited, perhaps, significantly, e.g., below 1 kph. On the positive side it is a tractor mounted machine so it is conceptually easy for farmers to understand and is considered unlikely to meet uptake resistance due to it being different from other tractor operations.

The key issue with the ex-field approach is removing and replacing significant amounts of soil, approx. 80 tonne/ha, from fields, which is considered likely to face resistance among farmers as it is a novel approach - even though some crop harvests, e.g., potatoes can exceed that weight and with much larger volumes. There is also likely to be a sizeable amount of energy used by the tractors and machinery, to remove and replace the soil in the field, though this would be small compared with the energy used for soil heating in the in-field tunnel design. In addition, moving large amounts of soil poses a soil compaction risk if not correctly managed. On the plus side the energy efficiency of the treatment system would be exceptionally high due to the use of well insulated counterflow heat exchangers.

This supplemental report, outlines a hybrid of the above two concepts that marries the positives of both with none of the negatives. It is noted that this is in disagreement with section 4.2.4.3, p 44, in the first report [1] which considered an in-field design that lifted the soil for processing was impractical. That analysis was based on removing only the soil in the intrarow, individually treating each row and then returning the same soil. A different approach is taken with this design that avoids these issues.

2. In-field out of soil design

The proposed design is a three point mounted system, based on the following parameters.

- Soil is removed from the field surface across the whole operating width of the machine. To remove enough soil to fill four 7 × 7 cm intrarows, on a 150 cm wide bed 1.3 cm depth of soil would need to be removed.
- The removed soil is then screened (e.g., a finger screen) to remove residues, stones and oversized soil crumbs.
- The residues, stones, etc., are then returned to the field, either across the whole machine width or into the wheelings.
- A small volume of screened soil will be held in a ‘pre-treatment hopper’ the level of which is automatically controlled by the above soil loading system by increasing or decreasing the volume of soil being removed from the field. This is required to ensure that sufficient volume of soil is continually available for heat treatment, despite the inevitable variance of the collection rate due to natural variability of soil in the field.



- Soil is then heat treated in the counterflow heat exchangers, either two heat exchangers in-series or a single-vessel two-stage heat exchanger (section 4.2, p 40, [1]).
- Soil is then placed in a second, small, 'post-treatment hopper', again, to ensure that the flow of soil being treated and that being placed back in the field can be maintained despite variations in flow rates between them.
- The treated soil in the post-treatment hopper is then placed into the intrarow.
- Seed drilling or planting machinery is attached to the rear of the soil treatment machinery so that accurate placement of the seed or plant in the centre of the treated soil is guaranteed.

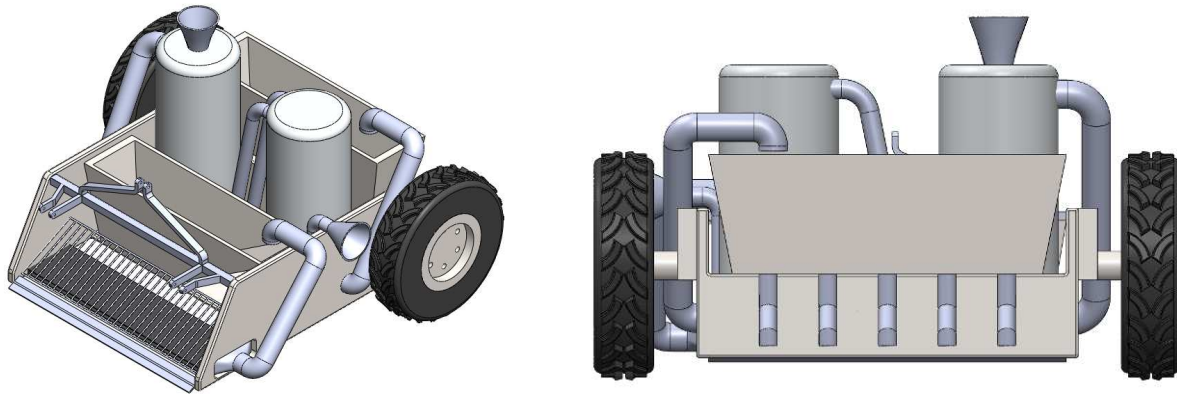

Figure 1. Conceptual drawing of soil thermal weeder

This approach solves the following issues:

- Having the machine tractor mounted addresses the conceptual uptake issue among farmers.
- Processing the soil in the field (in-situ) solves the problem of removing and replacing large amounts of soil to and from a field as in the ex-field system.
- Soil handling issues raised in the first report (section 4.2.4.3, p 44, [1]) are addressed as removing a thin slice off the whole bed is already achievable using current systems, e.g., onion lifters, and also addresses the problem of handling small volumes of soil as a larger single volume is picked up.
- Soil screening is also established technology (section 4.2.4.2, p 43, [1]) so there will be no problems with its implementation.
- Stones, residues and large soil crumbs that are problematic for the tunnel design are solved using the screening system.
- The use of small hoppers to balance soil flow rates between the different operations (soil removal, treatment, replacement) solves the soil displacement problem (section 4.2.4.3, p 44, [1]).
- The use of well insulated counterflow heat exchangers solves the heat loss issue associated with the in-field tunnel design.
- Integrating drilling and planting with the soil treatment operation solves the issue of requiring double steer GPS systems¹ to ensure the drill places the seed in the centre of the 5-7 cm wide treated soil band.
- Total energy use is minimised:
 - The heating process is as energy efficient as is physically possible
 - The minimum amount of soil is moved the smallest distance possible (i.e., through the machine) which reduced the energy used to move soil compared with an ex-field system

¹ Double steer GPS systems are where both the tractor and implement have their own, independent steering systems which allows millimetre accurate implement positioning.



- The machinery size and weight would be comparable to existing machinery, e.g., seed drills, so would not require large amounts of tractor power or particularly large tractors.
- With the high energy efficiency of the insulated counterflow heat exchangers, it becomes economically practical to heat the entire cropping surface to the maximum depth of weed emergence, e.g., 7 cm allowing broadcast and narrow row systems to take advantage of soil thermal weeding.

2.1. Remaining issue to address

The key remaining issue to be addressed is the ability to heat sufficient soil while achieving 100% weed seed mortality, that will give an acceptable working rate for farmers and growers. The key limitation of the heat exchangers is an upper temperature limit of 100°C because they are an enclosed vessel: heating the soil above 100°C will produce steam from soil water, which will increase the pressure unless it is vented, which will result in reduced efficiencies. Research is required to test the ability of the heat exchanger system to be able to effectively kill weed seeds. Options to improve the effectiveness of the heating system include such as microwave heat sources which will have a direct heating effect on soil borne seeds.



3. Conclusions

The above design is considered to address most of the final design issues of ISTW machinery bringing it close to being a reality. Considering the growing weed management problem [1] it is considered vital that the final research on the ability of counterflow heat exchangers to achieve 100% weed seed mortality while processing sufficient volumes of soil that achieves an acceptable work rate, is undertaken as soon as possible.

4. Acknowledgments

Dr Rainer Ramharter for the conversation that enabled the final parts of the ISTW puzzle to be put in place.

5. References

1. Merfield, C.N., Expanding the potential of intrarow soil thermal weeding. 2013, The BHU Future Farming Centre: Lincoln. <http://www.bhu.org.nz/future-farming-centre/information/weed-management/istw>
2. Merfield, C.N., Intrarow soil thermal weeding supplemental report: An analysis of the potential for ex-field heat treatment. 2013, The BHU Future Farming Centre: Lincoln. <http://www.bhu.org.nz/ffc/information/weed-management/istw/intrarow-soil-thermal-weeding-supplemental-report-an-analysis-of-the-potential-for-ex-field-heat-treatment-2013-ffc-merfield.pdf>

